

OASIS DP RO

Reverse Osmosis Units with Made in Italy components



OASIS DP - Reverse Osmosis Units

INSTALLATION, USE AND MAINTENANCE MANUAL

Dear Customer, thanks for choosing this Atlas Filtri product.

1. GENERAL INFORMATION

The indications in this manual apply to models:

OASIS DP STD
OASIS DP PUMP

OASIS DP is a device intended to process drinking water *able* to modify its organoleptic and chemical properties, reducing the saline content while guaranteeing microbiological safety.

Correct use and maintenance permit the reduction of most pollutants such as insecticides, pesticides, fertilisers, hazardous organic substances, heavy metals, pathogen micro-organisms.

1.1 SYMBOLS USED

GENERAL INFORMATION



Indicates a warning or note on key functions or helpful information.

Pay the utmost attention to text marked with this symbol.



Indicates a manual adjustment that may also require the use of portable equipment or tools.



A measurement must be taken, a signal checked or a visual inspection made.

HAZARD INDICATIONS



Generic hazard, with risk to the user.



Electrical hazard.

PROHIBITION INDICATIONS



Prohibited.

1.2 CONDITIONS OF USE



OASIS DP is not a drinking water maker. Do not use for uses intended for drinking water in the event of originally non-drinking water or of unknown quality.



Perform periodic routine maintenance to guarantee processed water drinking requirements and maintain the stated performance levels.

Use only with water with a pH between 6.5 and 9.5.

Observe the use limits indicated on the label.

Keep away from excessive heat and cold: min 4°C (39.2°F) - max 45°C (113°F).

In the event of prolonged disuse, remove the cartridges and membranes and, when reused, insert new ones. After servicing, let the water run for at least 5 minutes before using it.

➔ At the end of the OASIS device working life and relevant cartridges, membranes and UV lamps, discard according to current local law.

2. INSTALLATION

2.1 Preface

➔ Assembly and installation must be performed by qualified personnel according to current local regulations. Before performing any operation, carefully read the instructions in this manual. Keep the manual and protect it against anything that could compromise its legibility.

2.2 Main components

- 1 DP TRIO head for housings for filter cartridges
- 2 DP TRIO housing bowls for filter cartridges
- 3 RO VESSEL housing for osmosis membrane
- 4 AIC activated carbon post-filter
- 5 Booster pump (PUMP models)
- 6 AIM re-mineralising post-filter

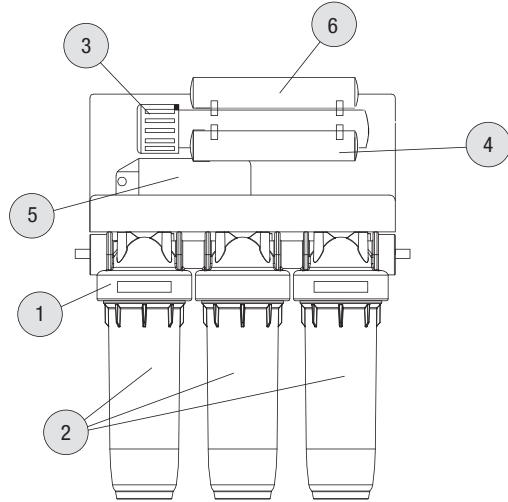

➔ The percentage of dissolved salt and other rejected elements depends on the water quality, temperature, pressure and total amount of dissolved salts and varies according to the type of salt or elements.

Processing particularly turbid water or with many impurities can clog filters and/or membranes with the consequent loss of water flow.



Sewage water, sea water or water with chemical, physical and bacteriological conditions that can not be subject to Reverse Osmosis (industrial water or chemical processing waste) cannot be processed.

2.4 Technical specifications (tab. A)

➔ Product use in working conditions other than the TECHNICAL SPECIFICATIONS is considered IMPROPER USE. The manufacturer cannot be held liable for any damages caused by improper use, by failure to observe what indicated in this manual, by repairs not performed by professionally qualified personnel or due to changes and alterations to the original device functions.

Oasis DP RO operation explained

Reverse osmosis is by far the most advanced water purification technology in use today. A special semipermeable membrane structure similar in its properties to the membrane of a living cell is capable of purifying drinking water from virtually all harmful impurities. The membrane can be thought of as having tiny pores, 200 times smaller than viruses and 4000 times smaller than bacteria.

Reverse osmosis membranes harness the principle of body's metabolism on a cellular level. Only molecules of certain size can penetrate cellular membrane.

The Oasis DP is a five-stage filtration unit. Using the feed water adapter and feed valve the water supply is connected to the pre-filtration housing head. Incoming water passes through pre-filter cartridges (5 micron polyspun, Granulated activated carbon, 5 micron carbon block) designed to remove solids (such as rust, sand, silt, etc), residual chlorine and organochlorines from water. After undergoing pre-treatment in the pre-filters, water enters into the fourth (and most important) stage: the reverse osmosis membrane installed in a special housing.

The inlet of membrane housing is connected through the feed side of auto shut-off valve. One of the two outlets supplies purified water (permeate), and the other carries away water with rejected impurities (concentrate). The membrane purifies water at the molecular level by passing through its pores only the water molecules and the molecules of dissolved oxygen.

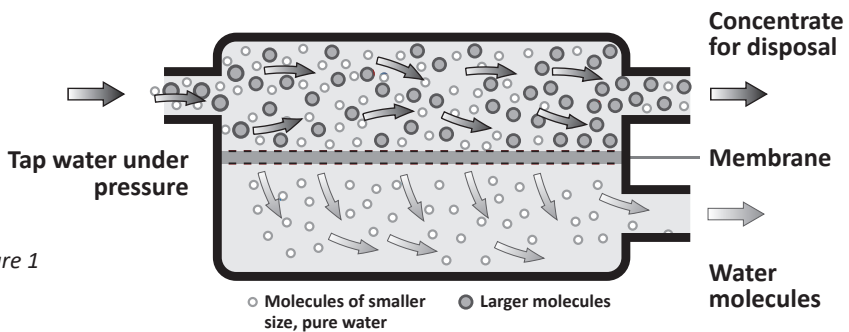

Figure 1

Inside the membrane, water is separated into two streams: concentrate, which is discharged into drain, and permeate, which enters pressure tank for storage.

The tank is connected to the output through the membrane auto shut-off valve and check valve built into the transition fitting that is installed in the permeate outlet of membrane housing. After the auto shut-off valve is installed the union tee, through which the tank is connected to the filter

The pressure tank accumulates purified water. Without it, the reverse osmosis membrane wouldn't be able to produce sufficient flow for direct water consumption. Thus, the tank stores a supply of purified water and delivers it to the user as needed, and then the unit generates a supply of water. Time required to fill empty tank can range from 1.5 to 3 hours. After the tank has been filled the auto shut-off valve shuts off the water supply from the pre-filters and the unit stops.

Whenever purified water is drawn off, the pressure of water in the tank lowers, and the auto shut-off valve automatically resumes the flow of water through the pre-filter cartridges to the membrane to re-fill pressure tank. Water with retained impurities (concentrate) is dis-charged into drain through the concentrate outlet which is installed on a drain pipe. In order to create the backpressure which is required to maintain the operating pressure inside the membrane housing, a orifice type flow restrictor is installed.

Finally, water is drawn through a carbon block post filter and a remineralising cartridge which improve the taste and add calcium and magnesium making the water suitable for drinking.

Fig. 1
Connection diagram

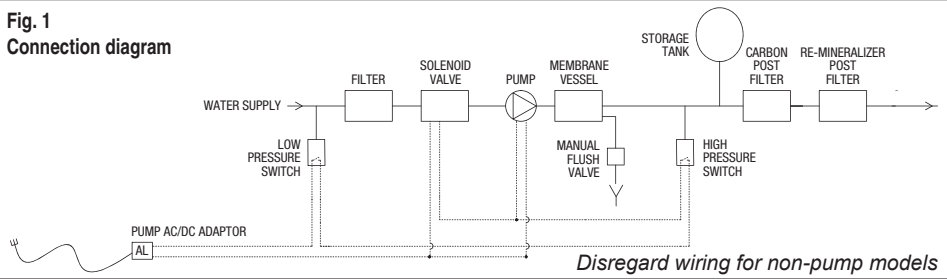

Auto shut off valve

Concentrate
Connect to drain



Connect to
pressure tank

Permeate
Connect to tap

Water Flow though Atlas Filtri Oasis RO Unit.

- 1/ Raw water enters the RHS of the triple pre-filter housing under the mounting plate; labeled, **FEED WATER IN**
- 2/ After Passing through the pre-filters, water exits from the LHS and is piped to a square white block behind the top horizontal filter housings. This block has arrows showing In /Out. This pipe should be connected on the **UPPER IN** port.
- 3/ Water exits from the **UPPER OUT** port of the square block, and connects to RHS side of Membrane Housing. Arrows on Membrane Housing indicate water goes Right to Left.

On LHS of Membrane housing there are two fittings, White and Blue

- **The White fitting goes to drain.** This must be unrestricted.
- The piping from the Blue fitting goes to the Square block, **LOWER IN** port.
Water exits the **LOWER OUT** port and connects to the Carbon Post-Filter RHS.



5/ Water flows right to left though the Carbon filter.

The inlet fitting of the Carbon Housing is fitted with a Tee.

The tee connects to the 12L Pressure tank supplied with unit.

6/ From left of Carbon filter, the pipe loops to connect into the Remineralisation filter housing on the LHS.

Water exits the RHS of the remineralisation filter **OUT** port labeled **"Faucet"**

Key Points

Because the processing speed of RO is very slow (around 130 to 750ml a minute) the unit is supplied with 1a 2L pressure vessle to store the processed water for when it's needed.

When in use, stored processed water is drawn from tank. The tank is recharges between use.

- A 12L tank holds 4L, so if unit used a frequently, production may seem low.
- Max processing capacity up to 190L a day.
- For every 1L of processed water, there is approximately 500ml of concentrate.

| | | Model | | | |
|--|-----------------------------|-------------|------|----------------|--|
| Technical Specification | Unit of Measure | STD | | PUMP | |
| Max dimensions (height x width x depth) | mm | 580x370x150 | | 580x370x150 | |
| Metal storage tank dimensions | mm | 280x345 | | 280x345 | |
| Weight | kg | 5 | | 7 | |
| Max daily production 50 GPD | l | 190 | | 190 | |
| Max daily production 100 GPD | l | 380 | | 380 | |
| Percent recovery | % | 20 | | 20 | |
| Saline rejection | % | 90 | | 95 | |
| Bacterial rejection | % | > 98 | | > 98 | |
| Feed water | Max. feed water TDS | mg/l (ppm) | 1000 | 1000 | |
| | Max. feed water temperature | °C | 30 | 30 | |
| | Min. feed flow | l/h | 100 | 100 | |
| | Min. feed pressure | bar | 3 | 1 | |
| | Max. feed pressure | bar | 8 | 3 | |
| UV | Electric power | | | | |
| | Rated voltage | V | | | |
| | Frequency | Hz | | | |
| | Absorbed current | A | | | |
| | Power | W | | | |
| Pump | Power type | | | Direct current | |
| | Rated voltage | V | | 24 | |
| | Head | psi | | 116 | |

2.5 Production installation



Before installation, make sure the plumbing system has been installed as for the existing rules of the state of the art.

Install a bypass that permits unit's by-passing.

Install a check valve from the unit to the water mains.

For mains pressure over 8 bar (116 psi) a pressure reducer must be installed upstream from the product. Protect the product against "water hammer" using an appropriate anti-water hammer system (expansion vessels, shock absorbers).

For mains pressure under 3 bar, install pump models (PUMP, PUMP-UV).



Presence and efficiency of the grounding of the power line.

Power line compatibility with the electrical specifications of booster pump (for PUMP models) and UV lamp (for UV models).

Power wires diameter over 1 mm.

Mains voltage stability (voltage peaks under 10%).

INSTALLATION DIAGRAM

- 1 Water supply
- 2 Processed water tap
- 3 Drain bracket
- 4 Storage tank tap
- 5 Booster pump

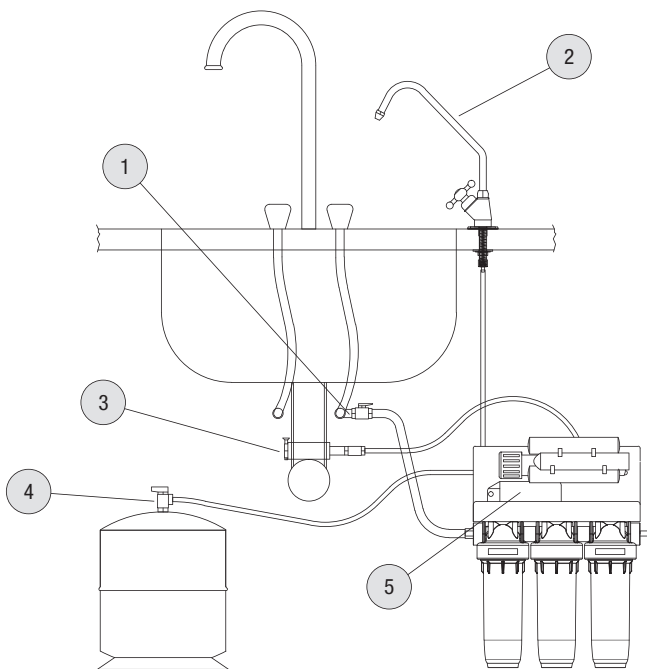

2.5.1 Typical installation with 1/2" MF water intake



Unscrew the cold water hose nut from the wall coupling.

With sealing tape (PTFE), install the 1/2" MF water intake with the 1/4" tap.

Reassemble the previously detached hose on the water intake male.

Connect the OASIS 1/4" hose to the water intake.

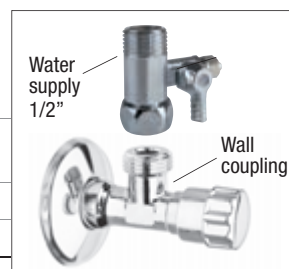

2.5.2 Drain bracket installation



Install the drain bracket on the sink drain siphon.

Make sure the gasket correctly rests on the pipe and that the bolts are tight.

Remove the drain pipe fastening nut.

Using a drill with a 6mm bit, drill a hole on the drain siphon pipe where the nut was just removed.

Insert the drain pipe in the nut by about 2 cm and screw the fastening nut onto the bracket.

Tighten the fastening nut and install the check valve with the arrow facing the bracket, as close to the drain as possible.

- 1 Drain pipe
- 2 Quick coupling
- 3 Drain bracket
- 4 Gasket
- 5 Bolt
- 6 Bolt lock nut
- 7 Sink drain siphon pipe

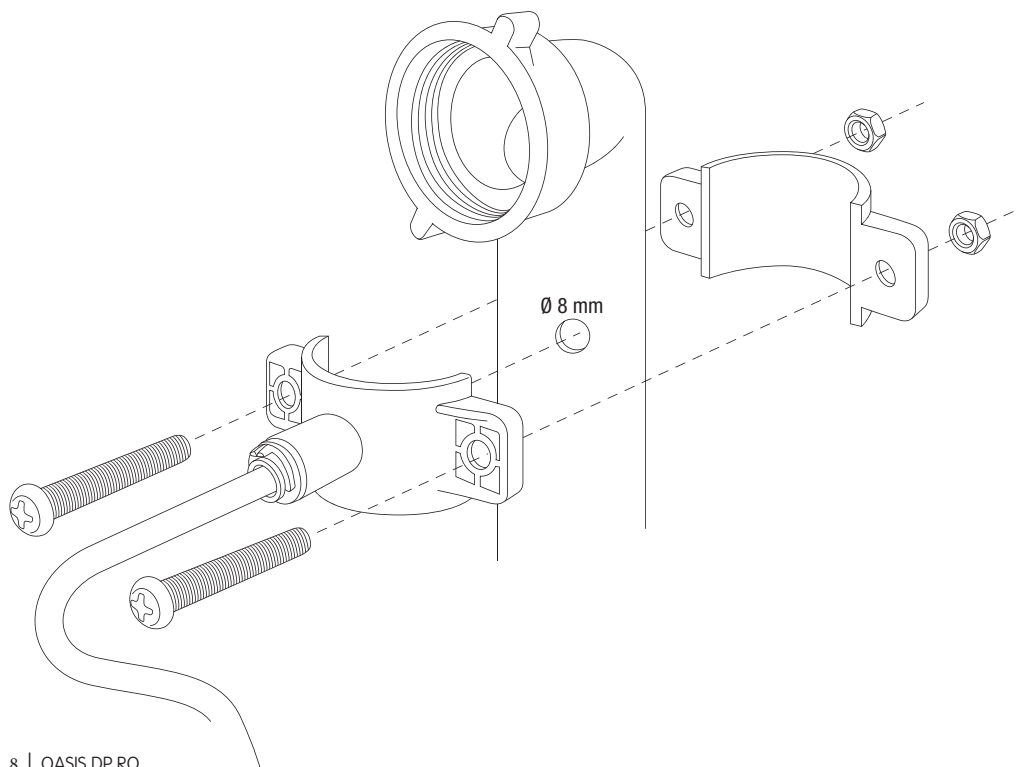
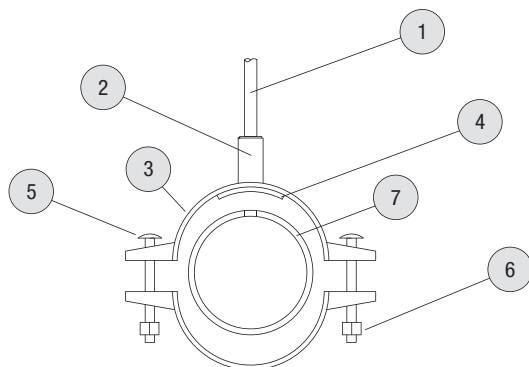

2.5.3 Storage tank installation



Place the tank near the machine.

Loosen the fastening nut on the tank ball valve.

Insert the 1/4" tank connection pipe and tighten the fastening nut.

Connect the 1/4" pipe to the machine.

2.5.4 Dedicated tap installation



Drill a 12mm diameter hole on the sink bottom (no. 6), remove any burrs with a round file.

Place the gasket (no. 5) with spacer (no. 4) and chrome-plated base (no. 3) on the hole, insert the threaded tap rod (no. 2).

ON the bottom side, insert in order the gasket (no. 7), elastic washer (no. 8) and screw in the fastening nut (no. 9).

Insert the pipe (no. 12) in the end nut (no. 11) and plastic ring (no. 10).

Tighten the end nut (no. 11) on the threaded tap rod (no. 2).

- 1 Tap
- 2 Threaded tap rod
- 3 Chrome-plated base
- 4 Spacer
- 5 Gasket
- 6 Sink base
- 7 Gasket
- 8 Elastic washer
- 9 Lock nut
- 10 Plastic ring
- 11 End nut
- 12 1/4" permeated pipe

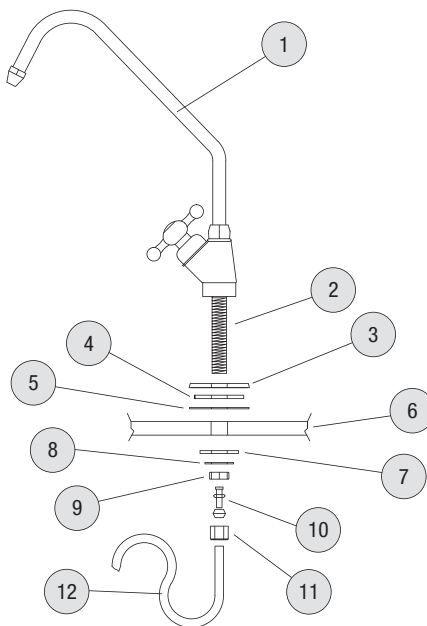

2.5.5 membrane and filter cartridge installation

To install the membrane, see paragraph 3.2: "Membrane replacement".

To install the filter cartridge, see paragraph 3.3: "Filter cartridge replacement".

WARNING: using cartridges other than original ones voids the warranty.

2.6 Start up



The OASIS DP osmotic membrane is supplied dampened with a maintenance s

Before using water, run for at least 10 - 15 minutes, flowing from the dedicated tap

Prevent the membrane from drying by leaving in the sealed package until use.
Install the membrane immediately after opening the package.



Replacement membrane PN 807277

3. ROUTINE MAINTENANCE



Before performing any routine maintenance, make sure the power cord is unplugged.

Routine maintenance only refers to consumable part replacement.

We recommend routine maintenance be performed at least once every 3 months.

| ELEMENT TO BE CHECKED | CHECK | FREQUENCY |
|--------------------------|---|----------------|
| Unit | Visually check integrity and conditions General cleaning Functional check | 3-6 months (*) |
| Filter cartridges | Replacement | 3-6 months (*) |
| AIC and AIM post-filters | Replacement | 3 months (*) |
| RO Membrane | Replacement | 3 years (*) |

(*) Special water conditions may require more frequent maintenance.



The PUMP, model electrical devices are powered with 220 - 240V - 50 Hz electrical current.
Before performing any maintenance, make sure the power cord is unplugged.



To clean the device, do not use corrosive or acidic products or steel wool or steel brushes.
Do not clean the device with direct jets of water or at high pressure.

3.2 Osmotic membrane replacement



Run water from the tap over the sink to reduce circuit pressure.

Disconnect the connection pipe on the RO VESSEL top.

Unscrew the RO VESSEL top.

With a clamp, remove the membrane.

Insert a new membrane.

Screw in the RO VESSEL top.

Insert the connection pipes.

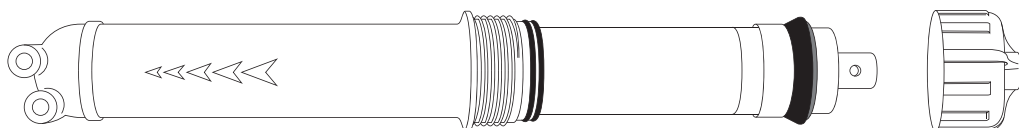

3.3 Filter cartridge replacement

Original cartridges are available in practical and convenient KITS.

OASIS DP models - **OASIS DP cartridge KIT** -

1. SEDIMENT - PP melt blown filter 5 micron
2. CTO Chlorine-Taste-Odor carbon G.A.C.
3. VOC Volatile-Organic-Compound carbon block filter 5 micron



Replacement pre-filter kit PN 807276

The average filter cartridge working life varies according to use, environmental conditions, pressure, etc. In general, changes in water taste, odour and colour indicate that the cartridge requires replacement.

- A. Before opening the container, turn off water supply tap and place a container under the system to collect any water that may spill when the cartridges are removed.
- B. Release product pressure by opening a downstream tap.
- C. Open the filter housing by unscrewing the bowl from the top.
- D. Remove the used cartridge.
- E. Gently clean the bowl with cold water and a soft sponge.
- F. Remove the protective film from the new cartridge.
- G. Insert the new cartridge in the bowl.
- H. Lubricate the bowl o-ring with the lubricant included in the package (Lubrikit). If the o-ring appears damaged, replace it with a new o-ring (o-ring included in the package) and lubricate with Lubrikit.
- I. Screw the bowl onto the head and tighten with a wrench, do not over tighten. If the wrench is not included in the package, purchase it separately.
- J. Slowly open the main water tap.
- K. Let water flow for about 5 minutes from a tap downstream from the product before use. This also allows air purge of the product.



Using cartridges other than original ones voids the warranty.

3.4 AIC activated carbon post-filter replacement



Remove the blue safety rings from the post-filter quick-fits (input and output).

Press the quick-fits coupling release ring to remove the input and output pipes.

Extract the used post-filter from the bracket and replace it with a new AIC post-filter (only use original spare parts or the warranty is voided).

Fit the pipes in the input and output, making sure the pipes are securely locked in the quick-fit.

Re-insert the safety rings in the quick-fits.

3.5 AIM re-mineralising post-filter replacement

Perform the replacement steps as in the procedure described in point 3.4.

4. NON-ROUTINE MAINTENANCE



Non-routine maintenance (repairs and/or replacement of non consumable parts) must be performed by personnel qualified by the manufacturer and accredited distributors, or the warranty is void.

DATE

WORK TYPE

TROUBLESHOOTING

OASIS DP devices are constructed following strict quality controls and are subject to stringent efficiency and resistance tests. Following are a series of problems that may occur due to incorrect installation or maintenance or improper use, possible negligence or due to filter or part wear.

- Incoming water pressure requirement for non-pump RO model is 3 to 8 bar
- Limit incoming pressure to between 1 and 3 bar for RO unit with fitted pump

Problem: The unit does not deliver water.

| Cause | Solution |
|------------------------------|---|
| Inlet tap turned-off. | Turn-on the inlet tap. |
| Insufficient input pressure. | Make sure supply water mains pressure is not under 3 bar (43.5 psi) in models without pump and 0.5 bar (7.2 psi) in models with pump. |
| Filters clogged. | Check filter cartridge conditions; replace if clogged. |
| Shut-off valve broken. | Replace the shut-off valve (see section 4 non-routine maintenance). |
| Membrane clogged. | Replace the membrane. |
| Booster pump broken. | Replace the pump (see section 4 non-routine maintenance). |

Problem: The device continuously discharges water.

| Cause | Solution |
|-------------------------|---|
| Hydraulic circuit leak. | Check pipes and quick-fits and look for leaks. |
| Shut-off valve broken. | Replace the shut-off valve (see section 4 non-routine maintenance). |

Problem: Delivered water has an unpleasant taste.

| Cause | Solution |
|---|---|
| AIC active carbon post-filter depleted. | Replace the AIC post-filter. |
| Storage tank bacterially polluted. | Replace the storage tank (see section 4 non-routine maintenance). |
| RO membrane fault. | Replace the RO membrane. |

Problem: The booster pump does not start when dedicated (processed water) tap is turned-on.

| Cause | Solution |
|----------------------------|---|
| No power supply. | Make sure the power cord is plugged in and there is power. |
| Pump broken. | Replace the pump (see section 4 non-routine maintenance). |
| Incorrect wiring. | Check pump and pressure gauge wiring in diagram 2.3. (see section 4 non-routine maintenance). |
| Pump AC/DC adaptor broken. | Replace the pump AC/DC adaptor (see section 4 non-routine maintenance). |

Problem: With dedeicated (processed water) tap turned-off, the booster pump restarts for several seconds.

| Cause | Solution |
|-------------------------|--|
| Hydraulic circuit leak. | Check the hydraulic circuit to the drain tap and look for leaks. |

| | Parameter | Value |
|---|---|-------------------------------|
| 1 | Main pressure (no booster pump), barg (psi) | 3-6* (43-87) |
| 2 | Main pressure (booster pump installed), barg (psi) | 2-4.5 (29-65) |
| 3 | Tank bladder pressure, barg (psi) | 0.4-0.6** (5.8-8.7) |
| 4 | Feed water temperature, °C (°F) | +4...+30*** (39...86) |
| 5 | Weight of the system (base model), kg (pounds) | 6 (13.2) |
| 6 | Ambient temperature, °C °F | +5...+40*** +41...+104 |
| 7 | Water supply connection | ½" thread |
| 8 | Filter dimensions, H×W×D (basic assembly), mm inch | 350x450x150 13.8x17.7x5.9 |
| 9 | Tank dimensions, H×W×D, mm inch | 350x260x260 13.8x10.2x10.2 |

* If supply water pressure is below required value, purchase pumped model or fit your existing filter with booster pump. If the pressure in the water system is above the limit, it is necessary to install a pressure regulator on the main pipe.

** If pressure in tank bladder is outside this range, it is necessary to pump up or release the pressure until it conforms to the requirement.

*** If supply water temperature is up in the range of +20...+30 °C (+68...+86 °F), rejection of impurities will be decreased and system capacity increased, bringing about an increase in TDS. Using the product with supply water temperature in excess of +30 °C (+86 °F) is not recommended.

SUPPLY WATER QUALITY REQUIREMENTS*

| | Index | VALUE** |
|---|-----------------------------|--------------------------------------|
| 1 | pH | 6.5-8.5 |
| 2 | TDS | <1500 ppm |
| 3 | Hardness | <500 ppm CaCO ₃ (<28 °dH) |
| 4 | Free chlorine | <0.5 ppm |
| 5 | Iron | <0.3 ppm |
| 6 | Manganese | <0.1 ppm |
| 7 | Chemical oxygen demand | <5 ppm O ₂ |
| 8 | Total bacterial count (TBC) | <50 CFU/mL |
| 9 | E. coli titer | <3 |

Do not use with water that is microbiologically unsafe or of unknown quality without adequate disinfection before or after the system.

* If water supply does not meet the requirements, service life of membrane and/or pre-filter cartridges may be shortened.

** If your home is supplied with raw wellwater, perform laboratory test of your water before installing a reverse osmosis filter. If any of your water indices exceed the limit, consider using a water treatment system to correct supply water quality. Refer to water treatment specialists or companies for advice and proper equipment selection.

WATER QUALITY AFTER REVERSE OSMOSIS MEMBRANE*

| | Index | Value |
|---|--------------------|----------|
| 1 | pH | 5.5-6.5 |
| 2 | TDS | 5-15 ppm |
| 3 | Calcium | <2 ppm |
| 4 | Magnesium | <1 ppm |
| 5 | Sodium + Potassium | <5 ppm |

* Values are determined under the following conditions: temperature of supply water is 25 °C (77 °F), supply water quality and operation conditions correspond to manufacturer's requirements.

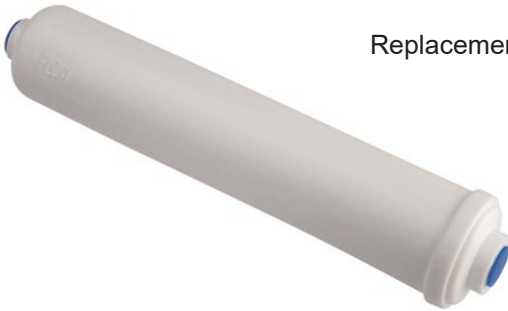

Replacement Carbon Post Filter PN 807278

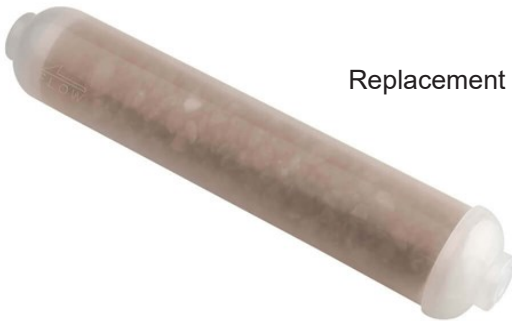

Replacement Remineralising Cartridge PN 807279

Underbench RO Spares & Accessories

| IMAGE | PART NUMBER | ITEM CODE | DESCRIPTION |
|---|--------------------------------------|-----------|---|
|  | ATL-DOUBLECLIP2.5"X2" | 807280 | Double Clip 2.5" for Oasis DP RO |
|  | ATL-SINGLECLIP2.5" | 807281 | Single Clip 2.5" for Oasis DP RO |
|  | ATL-MAXPRESSURESWITCH | 807282 | Max pressure switch for Oasis DP RO |
|  | ATL-MINPRESSURESWITCH | 807283 | Min pressure switch for Oasis DP RO |
|  | ATL-SOLENOIDVALVEPUMPANDPUMPUVMODELS | 807284 | Solenoid valve for Oasis DP Trio 50 Pump |
|  | ATL-SHUTOFFVALVESTDANDUVMODELS | 807285 | Shut-off valve for Oasis DP Trio 50 STD |
|  | ATL-ORINGKITFORROVESSEL | 807286 | O-ring kit for Oasis DP RO Vessel |
| | ATL-ORINGKITFORDPTRIO | 807291 | O-ring kit for Oasis DP Pre-filter TRIO |
|  | ATL-ROVESSEL | 807287 | Oasis DP RO Vessel |
|  | ATL-SPANNERFORROVESSEL | 807288 | Spanner for Oasis DP RO Vessel |
|  | ATL-XSPANNERFORDPTRIO | 807240 | Spanner for Oasis DP RO Pre-filter Housings |
|  | ATL-FILTERFITCARTRIDGECENTRINGDEVICE | 807290 | Cartridge Centring Device for Oasis DP RO |
|  | ATL-BOOSTERPUMPKIT | 807405 | Booster Pump Kit for Oasis DP RO |
|  | ATL-1/4" TUBING | 807437 | 1/4" Tubing Per Metre |
|  | ATL-TAPOASIS | 807445 | Tap |
|  | ATL-INLETVALVEOASIS | 807446 | Inlet Valve |
|  | ATL-TANKVALVEOASIS | 807448 | Tank Valve Junction 1/4 Hose |
|  | ATL-MALEELBOWCHECK1/81/4OASIS | 807449 | Male Elbow 1/8T 1/4H Check Valve |
|  | ATL-DRAINCLAMPOASIS | 807450 | Drain Clamp |
|  | ATL-FLOWREGULATOROASIS | 807451 | Inline Flow Regulator |
|  | ATL-FEMALESTR1/41/4OASIS | 807452 | Female Straight 1/4T 1/4H |

Oasis DP Underbench RO Spares & Accessories Continued

| IMAGE | PART NUMBER | ITEM CODE | DESCRIPTION |
|-------|--------------------------|-----------|----------------------|
| | ATL-MANUALFLUSHOASIS | 807453 | Manual Flush Valve |
| | ATL-STRAIGHT1/41/4OASIS | 807455 | Straight 1/4T 1/4H |
| | ATL-MALETEE1/41/4OASIS | 807456 | Male Tee 1/4T 1/4H |
| | ATL-ELBOW1/4OASIS | 807457 | Elbow 1/4H |
| | ATL-MALEELBOW1/81/4OASIS | 807458 | Male Elbow 1/8T 1/4H |
| | ATL-MALEELBOW1/41/4OASIS | 807459 | Male Elbow 1/4T 1/4H |
| | ATL-MALETS1/41/4OASIS | 807460 | Male TS 1/4T 1/4H |
| | ATL-TJUNCTION1/4OASIS | 807461 | T Junction 1/4H |
| | AF-OASISROTANK4GAL | 811009 | RO Pressure Tank 16L |

Underbench RO Replacement Cartridges

| IMAGE | PART NUMBER | SELECTION GUIDE | ITEM CODE | DESCRIPTION |
|-------|----------------------------------|-----------------|-----------|--|
| | ATL-CARTRIDGESKITFOROASISDP | | 807276 | Pre-filter cartridge trio kit for Oasis DP RO & Ecosoft Under Bench RO (5 mic PS, GAC, 5 mic CB) |
| | ATL-ROMEMBRANE50GPD1812 | | 807277 | RO 189lpd Membrane for Oasis DP RO & Ecosoft Under Bench RO |
| | ATL-AICACTIVATEDCARBONPOSTFILTER | | 807278 | Carbon Post Filter for Oasis DP RO & Ecosoft Under Bench RO |
| | ATL-AIMREMINERALIZERPOSTFILTER | | 807279 | Remineraliser Post-Filter for Oasis DP RO & Ecosoft Under Bench RO |



WHITE INTERNATIONAL PTY LTD

60 Ashford Ave Milperra NSW 2214 PO
Box 304 Milperra NSW 2214
Phone 02 9783 6000 Fax 02 9783 6001
Customer Service 1300 783 601
Email Sales: pumpsales@whiteint.com.au
www.whiteint.com.au

WHITE INTERNATIONAL NZ LTD

15G Kerwyn Avenue
East Tamaki, Auckland 2013, New Zealand
Phone 09 579 9777 Fax 09 579 7775
Customer Service 0800 509 506 Customer
Service Fax 0800 804 344 Email Sales:
sales@whiteint.co.nz
www.whiteint.co.nz

ATLAS FILTRI and SANIC are registered trade marks of ATLAS FILTRI S.r.l.

Unauthorized use of the registered trade marks is strictly forbidden and legally persecuted.

Images and texts are property of ATLAS FILTRI S.r.l., which reserves the rights to change products design and specification without prior notice.

